

**Grove Aircraft LGS, Inc.
1800 Joe Crosson Drive
El Cajon, CA 92020**

**ICA for the installation of
the Grove Disc Brake Conversion
in Piper PA-18 Series Airplanes
Doc No.: CDP2337-00024 Revision B**

Instructions for Continued Airworthiness

for the installation of

THE GROVE DISC BRAKE CONVERSION

in all

**PIPER AIRCRAFT INCLUDED
IN THE FAA APPROVED MODEL LIST**

when installed

In Accordance With

Supplemental Type Certificate No. SA01704LA
(FAA Project No. ST10691LA-A)

Doc No.: CDP2337-00024 Revision B

Grove Aircraft LGS, Inc 1800 Joe Crosson Drive El Cajon, CA 92020	ICA for the installation of the Grove Disc Brake Conversion in Piper PA-18 Series Airplanes Doc No.: CDP2337-00024 Revision B
--	---

RECORD OF REVISIONS

This "Record of Revisions" identifies all revisions to this manual. When changes to this manual are needed, revisions will be issued by the Supplemental Type Certificate holder.

This "Record of Revisions" shall remain in this manual at all times. Upon the receipt of revisions, insert the revised page(s) into this manual and enter the revision number, revision date, insertion date and signature of person incorporating the revision into the manual in the appropriate spaces below.

Revision Number	Pages Affected	Revision Date	Inserted By
IR	All	12/08/04	Ian Hollingsworth
A	All	08/14/07	Paul Nanney
B	All	07/30/10	Paul Nanney

TABLE OF CONTENTS

Section	Page
Title Page.....	1
RECORD OF REVISIONS.....	2
TABLE OF CONTENTS.....	3
LIST OF EFFECTIVE PAGES.....	4
INTRODUCTION.....	5
REVISIONS.....	5
DESCRIPTION AND OPERATION.....	6
1. Description.....	6
2. Operation.....	7
3. Airworthiness Limitations.....	7
MAINTENANCE PRACTICES.....	8
1. Access Panels.....	8
2. Removal.....	8
3. Disassembly.....	8
4. Cleaning, Inspection and Repair.....	8
5. Assembly.....	9
6. Installation.....	9
7. Inspection of Brake Linings.....	9
8. Installation of Brake Linings.....	9
9. Brake System Bleeding.....	10
10. Excessive Pedal Travel.....	10
11. Trouble Shooting.....	11
INSPECTION REQUIREMENTS.....	13
1. Scheduled Inspections and Maintenance Checks.....	13
2. Inspection Form.....	14
Appendix A Approved Model List.....	16
Appendix B List of Applicable Publications (LOAP).....	16

Grove Aircraft LGS, Inc 1800 Joe Crosson Drive El Cajon, CA 92020	ICA for the installation of the Grove Disc Brake Conversion in Piper PA-18 Series Airplanes Doc No.: CDP2337-00024 Revision B
--	---

LIST OF EFFECTIVE PAGES

<u>PAGE</u>	<u>DESCRIPTION</u>	<u>DATE</u>
1	Title Page	July 10, 2010
2	Record of Revisions	July 10, 2010
3	Table of Contents	July 10, 2010
4	List of Effective Pages	July 10, 2010
5	Introduction	July 10, 2010
6	Description & Operation	July 10, 2010
7	Operation, Limitations	July 10, 2010
8	Maintenance Practices	July 10, 2010
9	Maintenance Practices	July 10, 2010
10	Maintenance Practices	July 10, 2010
11	Troubleshooting	July 10, 2010
12	Troubleshooting	July 10, 2010
13	Inspection Requirements	July 10, 2010
14	Inspection Form	July 10, 2010
15	Inspection Form	July 10, 2010
16	Appendix A – FAA Approved Model List	July 10, 2010
16	Appendix B - List of Applicable Publications	July 10, 2010

Grove Aircraft LGS, Inc 1800 Joe Crosson Drive El Cajon, CA 92020	ICA for the installation of the Grove Disc Brake Conversion in Piper PA-18 Series Airplanes Doc No.: CDP2337-00024 Revision B
--	--

INTRODUCTION

This Instructions for Continued Airworthiness document has been developed using the guidelines in Appendix “G” of FAR Part 23 as required by FAR 21.50 and 23.1529.

This document is designed to provide aircraft technicians with sufficient information to inspect, troubleshoot, adjust, repair, test, remove, and install the components of the Grove Disc Brake Conversion installed in accordance with FAA Supplemental Type Certificate No. SA01704LA.

The Grove Brake Conversion is eligible for installation on the airplanes listed on FAA STC No. SA01704LA Approved Model List. See [Appendix A](#) of this document. The installation applies only to aircraft that have hydraulic brake systems installed.

See the List of Applicable Publications (LOAP) as [Appendix B](#) of this document. The publications listed in the LOAP constitute the required information essential for continued airworthiness for the aircraft.

The information in this document supplements or supercedes the original manufacturer’s maintenance manual only in those areas listed. For limitations, procedures and other information not contained in this document, refer to the aircraft manufacturer’s maintenance manuals, illustrated parts manuals and wiring diagrams or the vendor manuals as listed in the LOAP.

REVISIONS

For continuous use of this document, this document must be maintained in current revision status. The “List of Effective Pages” found on page 4 of this document, specifies the current effective date for each page of the document. Each time the STC holder finds it necessary to revise this document, a revision will be distributed to all users of the STC. Upon receipt of the revision, the revised pages should be inserted into this document, the old pages should be discarded and the “Record of Revisions” page should be completed by the person inserting the revision.

It is the responsibility of the person(s) performing maintenance on the installed system to ensure that this document is current prior to performing this maintenance. The current revision number may be verified by contacting the STC holder, Grove Aircraft Landing Gear Systems Inc., 1800 Joe Crosson Drive, El Cajon, CA 92020.

Telephone 619-562-1268 – Facsimile 619-562-3274

DESCRIPTION AND OPERATION

1. Description

1.1 General

The Grove Disc Brake Conversion consists of a single disc type brake at each main wheel. The disc is riveted to the wheel, while the brake assembly floats laterally on torque pins, which extend through a stationary torque plate, bolted to the axle. This conversion is compatible with all mineral fluids used in the original installations.

1.2 Major Components

One Caliper Assy P/N 30-5(A), 30-6A, 30-7A
 One Press Plate Assy P/N 11-1
 One Back Plate Assy P/N 10-1
 One Torque Plate Assy P/N 020-042(A)
 One Brake Disc P/N 018-013
 Six Rivets P/N AN441-6-6P

1.3 Illustrated Parts List

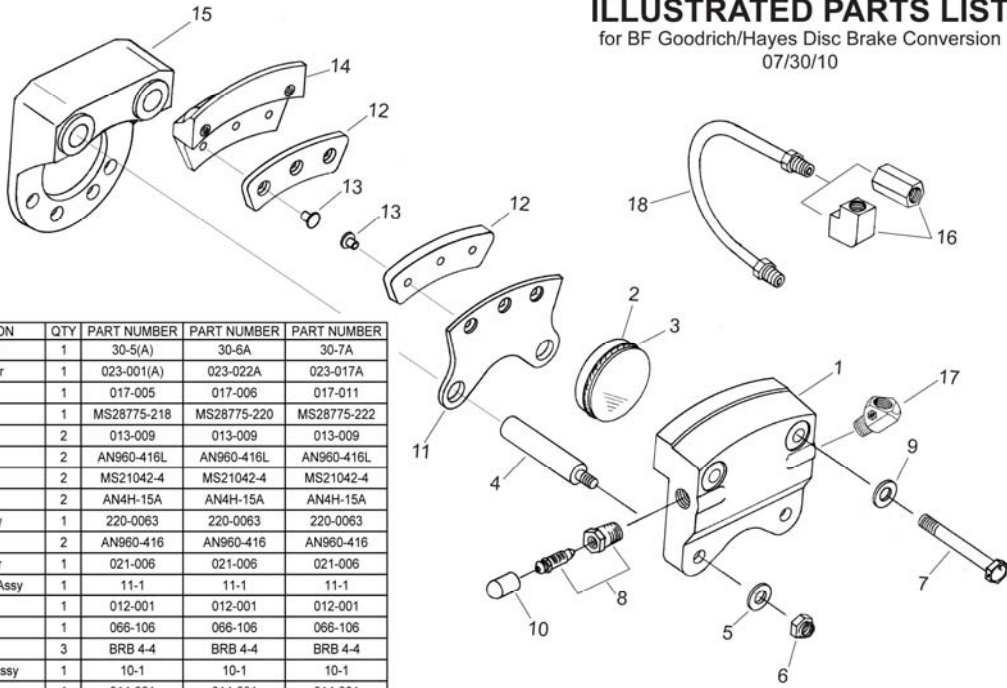

ILLUSTRATED PARTS LIST
 for BF Goodrich/Hayes Disc Brake Conversion
 07/30/10

FIG	DESCRIPTION	QTY	PART NUMBER	PART NUMBER	PART NUMBER
	Caliper Assy	1	30-5(A)	30-6A	30-7A
1	Body, Caliper	1	023-001(A)	023-022A	023-017A
2	Piston	1	017-005	017-006	017-011
3	O-Ring	1	MS28775-218	MS28775-220	MS28775-222
4	Torque Pin	2	013-009	013-009	013-009
5	Washer	2	AN960-416L	AN960-416L	AN960-416L
6	Nut	2	MS21042-4	MS21042-4	MS21042-4
7	Bolt	2	AN4H-15A	AN4H-15A	AN4H-15A
8	Bleeder Assy	1	220-0063	220-0063	220-0063
9	Washer	2	AN960-416	AN960-416	AN960-416
10	Cap, Bleeder	1	021-006	021-006	021-006
	Press Plate Assy	1	11-1	11-1	11-1
11	Press Plate	1	012-001	012-001	012-001
12	Pad	1	066-106	066-106	066-106
13	Rivet	3	BRB 4-4	BRB 4-4	BRB 4-4
	Back Plate Assy	1	10-1	10-1	10-1
14	Back Plate	1	014-001	014-001	014-001
12	Pad	1	066-106	066-106	066-106
13	Rivet	3	BRB 4-4	BRB 4-4	BRB 4-4
15	Torque Plate Assy	1	020-042(A)	020-042(A)	020-042(A)
16	Elbow Union	1	502x4	502x4	502x4
	Straight Union	ALT	302x4	302x4	302x4
17	45° Elbow	1	352x4	352x4	352x4
18	Line Assembly	1	007-001	007-001	007-001



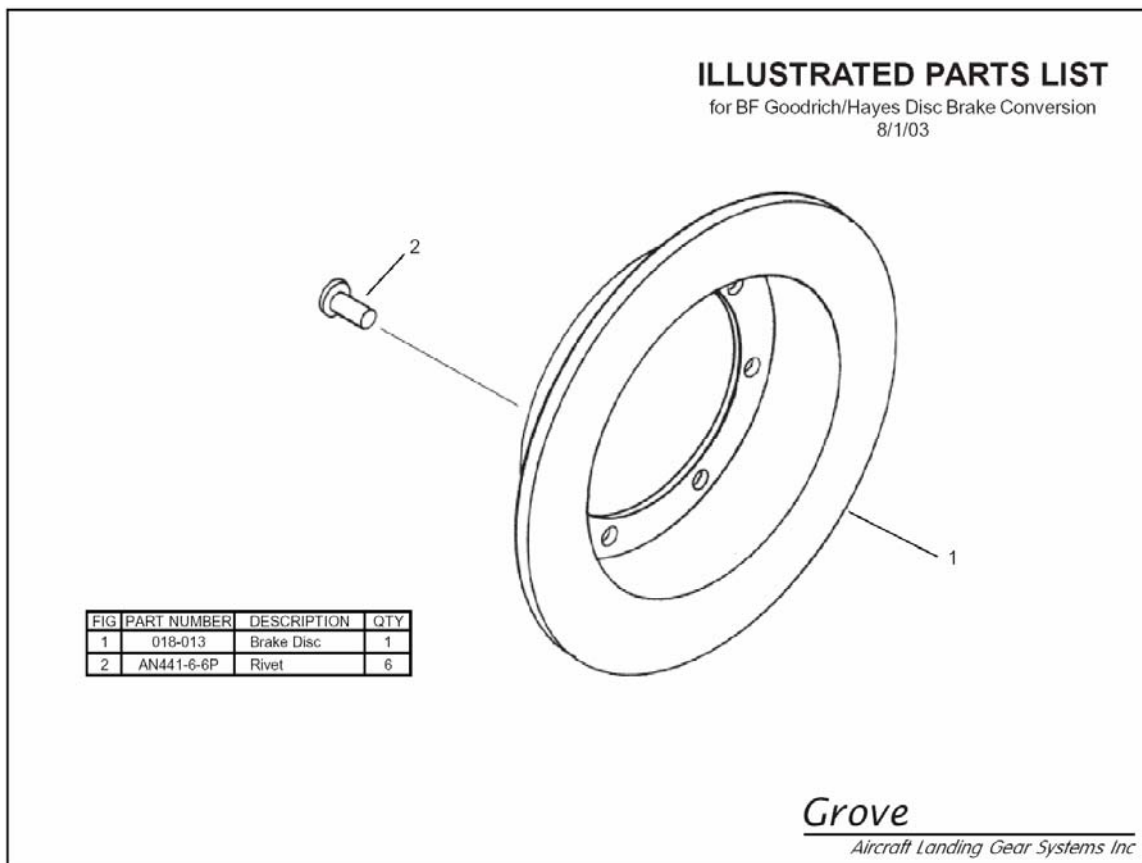

2. Operation

Operation of the Grove Disc Brake Conversion is identical to the operation of the original 4" BF Goodrich factory-installed brakes.

3. Airworthiness Limitations

No additional Airworthiness Limitations have been issued due to the installation of the Grove Disc Brake Conversion. The Airworthiness Limitations section is FAA approved and specifies maintenance required under § 43.16 and 91.403 of the Federal Aviation Regulations unless an alternative program has been FAA approved.

MAINTENANCE PRACTICES

1. Access Panels

There are no access panels involved in the installation or maintenance of this system.

2. Removal

- 2.1. Disconnect and drain brake line. Protect line and fitting from dirt.
- 2.2. Remove back plate.
- 2.3. Pull brake assembly out of torque plate to remove.

NOTE: The disc is riveted to the wheel and should not be disassembled unless in need of replacement.

3. Disassembly

Refer to Wheel Assembly Drawing which may be used as a guide during disassembly.

NOTE: Use of compressed air applied to the brake line fitting is permissible when removing the piston from brake cylinder.

4. Cleaning, Inspection and Repair

- 4.1. Clean all parts except brake linings and O-rings in EPA approved cleaning solvent and dry thoroughly.
- 4.2. O-rings are usually replaced at each overhaul. If their re-use is necessary, they should be wiped with a clean oiled cloth and inspected for damage.

NOTE: Thorough cleaning is important. Dirt and chips are the greatest cause of malfunctions in hydraulic brake systems.

- 4.3. Check brake linings for deterioration and maximum permissible wear as prescribed in paragraph 7.
- 4.4. Inspect brake cylinder bore for scoring. A scored cylinder may leak or cause rapid O-ring wear. A scored cylinder should be replaced.
- 4.5. If the torque pins are nicked or gouged, they should be sanded smooth to prevent binding with the pressure plate or torque plate. If the torque pins need to be replaced, they should be pressed out. New torque pins can be installed by tapping them into place with a soft hammer.

- 4.6. Inspect brake discs. Small nicks and scratches should be sanded smooth. If excessively warped, scored, pitted or rusted, the brake discs should be replaced with new parts. Brake discs should be replaced when the disc thickness falls below 0.170 inches. If replacement is required, replace disc in accordance with Installation Instructions Document #76600.
- 4.7. Check brake disc to ensure that it is securely attached to the wheel. Any loose rivets should be replaced in accordance with installation instructions.

5. Assembly

Lubricate O-rings with hydraulic fluid during assembly to prevent damage to them. Refer to Illustrated Parts List, Paragraph 1.3 above as a guide during assembly.

6. Installation

- 6.1. If the torque plate was removed, install on the axle in accordance with STC installation instructions.
- 6.2. Place brake assembly in position.
- 6.3. Install back plate.
- 6.4. Connect brake line.
- 6.5. Fill and bleed brake system as described in paragraph 9. This conversion is compatible with all mineral fluids used in the original installations.

7. Inspection of Brake Linings

Brake linings should be replaced when they are worn to a minimum thickness of 3/32 inch. Visually compare a 3/32 inch strip of material or the shank end of a 3/32" or #42 drill bit held adjacent to each lining to measure the thickness of the lining.

8. Installation of Brake Linings

Use 066-106 brake linings.

Proper installation will require the use of a special brake rivet setting tool, such as tool #824 which is available from Grove Aircraft Landing Gear Systems Inc. This kit consists of an anvil and a punch.

- 8.1. Remove bolts, washers and back plate.

- 8.2. Pull brake caliper out of torque plate and slide press plate off torque pins.
- 8.3. Remove all rivets securing linings to back plate and press plate. This can be accomplished using the brake rivet setting tool, a 9/64" punch or 9/64" drill.
- 8.4. Clamp flat sides of the rivet setting anvil in a vise.
- 8.5. Align new lining on back plate and place a brake rivets in each hole with rivet heads in lining.
- 8.6. Place rivet head against the anvil and center rivet setting punch on the lip of rivet. While holding back plate down firmly against lining, hit punch with a hammer to set each rivet. Repeat blows on the punch until lining is firmly against back plate.
- 8.7. Install new linings on press plate in the same manner.
- 8.8. Position press plate on torque pins and install brake caliper.
- 8.9. Install back plate with bolts and washers. Safety wire the bolts.

9. Brake System Bleeding

Standard bleeding, with a clean hydraulic pressure source connected to the wheel cylinder bleeder fitting is recommended.

- 9.1. Remove master cylinder filler plug.
- 9.2. Connect a clean hydraulic pressure source such as a hydraulic hand pump to the bleeder valve on the lower end of the wheel cylinder.
- 9.3. As fluid is pumped into the system, observe the level in the master cylinder.
- 9.4. When the master cylinder is full, tighten bleeder fitting and remove hydraulic pressure source.
- 9.5. Replace and tighten master cylinder filler plug.
- 9.6. Apply hard pressure to the brake pedal. Check to ensure that you have a "hard pedal" and that there are no leaks.
- 9.7. If a "soft pedal" condition exists, repeat steps (9.1) though (9.6).

10. Excessive Pedal Travel

NOTE: It is possible that an excessive pedal travel condition may exist. This is caused by the "free-play" between the brake pad and the brake disc. The pedal will travel (moving hydraulic fluid) until the brake pad contacts the brake disc, at which time a "hard pedal" condition will result.

- 10.1. In order to have a "hard pedal" at the top of the pedal travel, accomplish the following:
- 10.2. Jack the aircraft so that the wheel(s) are off the ground and able to rotate freely. This procedure may be achieved one wheel at a time.
- 10.3. Loosen and back-off the 2 AN4H-15A back plate tie bolts 1/16" - 1/8".
- 10.4. Attach your brake fluid filler source (pump) to the bleeder valve.
- 10.5. Open the bleeder valve and pump fluid into the system until the puck extends and the brake pad comes into contact with the brake disc.
- 10.6. Close the bleeder valve and disconnect the fluid pump.
- 10.7. Tighten both back plate tie bolts evenly until seated. You should not be able to rotate the wheel at this point.
- 10.8. Crack the bleeder valve and let just enough fluid escape to allow the wheel to rotate freely, with the brake pad still in loose contact with the brake disc.
- 10.9. Torque backplate tie bolts to 70-80 in-lbs and safety.

11. Trouble Shooting

Brake Assembly Troubleshooting

TROUBLE	PROBABLE CAUSE	CORRECTION
1. Unable to obtain sufficient hydraulic brake pressure or spongy pedal	Air in hydraulic system. Brake pedal binding	Check for source, then bleed hydraulic system IAW paragraph 9. Check for freedom of movement of brake pedal and master cylinder
2. Excessive pedal travel	Incorrect installation Leak in system—brake, master cylinder, fittings, or lines. Defective master cylinder. Back plate bolts loose.	Refer to paragraph 10. Locate leak and repair. Repair or replace. Torque bolts to proper value IAW paragraph 10.9.

Grove Aircraft LGS, Inc 1800 Joe Crosson Drive El Cajon, CA 92020	ICA for the installation of the Grove Disc Brake Conversion in Piper PA-18 Series Airplanes Doc No.: CDP2337-00024 Revision B
--	--

<p>3. Brake Drag</p>	<p>Piston jammed in caliper</p> <p>Foreign matter wedged in brakes</p> <p>Master cylinder not releasing hydraulic pressure</p> <p>Parking brake valve defective</p> <p>Foreign matter lodged between torque pins and torque plate bushings.</p> <p>Bent torque plate.</p> <p>Bent torque pins</p>	<p>Remove caliper and repair cylinder or piston</p> <p>Locate and remove</p> <p>Repair or replace master cylinder.</p> <p>Repair or replace parking brake valve.</p> <p>Clean and inspect IAW paragraph 4.5. Replace if necessary.</p> <p>Replace torque plate.</p> <p>Replace torque pins.</p>
<p>4. Rapid disc and/or pad wear.</p>	<p>Dragging brakes</p> <p>Excessive rusting, scoring, or pitting of brake disc</p> <p>Excessive back plate deflection caused by bent bolts or over torquing bolts.</p>	<p>Refer to Trouble #2</p> <p>Clean or replace disc.</p> <p>Check torque of bolts IAW paragraph 10.9 and replace bolts if bent.</p>
<p>5. Brakes won't hold.</p>	<p>Improper conditioning of brake pads.</p> <p>Contaminated pads.</p> <p>Insufficient hydraulic pressure.</p> <p>Brake pad carburized (overheated)</p>	<p>Condition pads IAW Installation Instructions.</p> <p>Replace pads.</p> <p>Refer to Trouble #1.</p> <p>Replace pads</p>

Grove Aircraft LGS, Inc. 1800 Joe Crosson Drive El Cajon, CA 92020	ICA for the installation of the Grove Disc Brake Conversion in Piper PA-18 Series Airplanes Doc No.: CDP2337-00024 Revision B
---	--

INSPECTION REQUIREMENTS

1. Scheduled Inspections and Maintenance Checks

This section of the document contains information regarding Time Limits – Inspection and Maintenance Checks, Overhaul and Replacement Items and Inspection Requirements.

1.1 Time Limits – Inspection and Maintenance Checks

Note: Recommended inspection/maintenance intervals do not guarantee that the item will function properly between inspection/maintenance checks.

The inspection intervals are based on average usage and environmental conditions.

Aircraft operated under extreme conditions, (extreme hot, extreme cold, high humidity, salty air, etc...), may require more frequent maintenance than the intervals specified in this document. The aircraft operator may perform more frequent inspection/maintenance checks based on his own usage.

The operator should perform the first inspection of the Grove Disc Brake Conversion installation to coincide with the next scheduled annual inspection of the aircraft and at each annual inspection thereafter, using the inspection form found in section 2 as a guide.

1.2 Overhaul and Replacement Items

There are no scheduled overhaul or replacement item requirements. Maintenance of the Grove Disc Brake Conversion components are “on condition”.

Grove Aircraft LGS, Inc. 1800 Joe Crosson Drive El Cajon, CA 92020	ICA for the installation of the Grove Disc Brake Conversion in Piper PA-18 Series Airplanes Doc No.: CDP2337-00024 Revision B
---	---

2. Inspection Form

The Grove Disc Brake Conversion is to be periodically inspected as required by paragraph 1.1 of this section of this ICA. The inspection form below is provided to assist maintenance and inspection personnel in incorporating the scheduled inspections into the aircraft inspection program.

This inspection form is provided only as a guide and checklist for inspecting the installed system.

Aircraft S/N: _____ Aircraft Registration No.: _____

Aircraft Total Time: _____ W/O No.: _____

BRAKE INSPECTION ITEMS Perform the following at each Scheduled Inspection of the Aircraft	Condition Sat/Un-sat	Technician Name/ Initials	Date
1. Inspect the torque plate and torque pins for proper mounting, security of attachment and corrosion.			
2. Inspect the brake caliper for freedom of motion and for hydraulic leaks.			
3. Check brake linings for deterioration and maximum permissible wear as prescribed in paragraph 7 on page 9 of ICA Number CDP2337-00024 Rev IR or later appropriate revision.			
4. Check the brake lines for chafing, damage and leaks.			
5. Inspect the brake discs for corrosion, wear and loose or missing rivets according to sections 4.6 and 4.7 on page 9 of ICA Number CDP2337-00024 Rev IR or later appropriate revision.			

Grove Aircraft LGS, Inc 1800 Joe Crosson Drive El Cajon, CA 92020	ICA for the installation of the Grove Disc Brake Conversion in Piper PA-18 Series Airplanes Doc No.: CDP2337-00024 Revision B
--	---

6. Check the master cylinders for security of mounting, general condition, and fluid level.			
7. Check pedal travel for a "hard pedal". If a pedal is "soft" or has excessive play, service the system according to paragraphs 9 and 10 on pages 10 and 11 of ICA Number CDP2337-00024 Rev IR or later appropriate revision.			

Grove Aircraft LGS, Inc. 1800 Joe Crosson Drive El Cajon, CA 92020	ICA for the installation of the Grove Disc Brake Conversion in Piper PA-18 Series Airplanes Doc No.: CDP2337-00024 Revision B
---	---

Appendix A Approved Model List

The Grove Brake Conversion is eligible for installation on the airplanes listed on FAA STC No. SA01704LA Approved Model List. The installation applies only to aircraft that have hydraulic brake systems installed.

Appendix B List of Applicable Publications (LOAP)

The publications listed in the LOAP constitute the required information essential for continued airworthiness of the aircraft.

Document Title	Document Number	Revision/Date
Instructions for Continued Airworthiness	CDP2337-00024	B / 07/30/10
Installation Instructions	76600	none / 07/30/10 or later appropriate revision